



AVK RESILIENT SEATED GATE VALVE Class 150

45/5D

To AWWA C509 (Non Rising Stem) Flanges & Drilling to ANSI B16.42, Class 150 Flat Face Valve sizes 2" to 16"

Use:

For water, sewage and neutral liquids to max. 70°C

Tests:

Hydraulic test to AWWA C509

Seat: 1 x Rwp = 250 PSI

Body: 2 x Rwp = 500 PSI

AVK SVMC test:

Hydraulic test to UL 2" to 12" 14" to 16"

Seat: 1.5 x Rwp = 375 300 PSI

Body: 2 x Rwp = 500 400 PSI

2" to 12" :

Rated working pressure (Rwp) = 250 PSI

14" to 16" :

Rated working pressure (Rwp) = 200 PSI

Materials:

Gland flange, body and bonnet Ductile iron GGG-50, EN1563

Gland flange bolts AISI 316

Coating Fusion Bonded epoxy Electrostatically applied

Stem Alu-Bronze

Stem sealing NBR wiper ring, 2 NBR O-rings

Wedge Ductile iron, GGG-50, core fully vulcanised with EPDM rubber, with integral wedge nut

Wedge Nut Bronze

Thrust collar and stem seal box Dezincification resistant brass, CZ 132 to BS 2874

Bonnet bolts AISI 316, A4

Bonnet gasket NBR rubber

Optional extras:

Handwheel

Extension spindle

Flange adaptor

Stem cap

Bonnet bolt: Stainless Steel AISI 304, A2

Approvals:



To AWWA C509 (Non Rising Stem) Flanges & Drilling to ANSI B16.42, Class 150 Flat Face
 Valve sizes 2" to 16"

Component list

- | | |
|----------------------|-------------------|
| 1. Stem | 8. Thrust collar |
| 2. Gland flange bolt | 9. Bonnet bolt |
| 3. NBR wiper ring | 10. Bonnet gasket |
| 4. Gland flange | 11. Wedge nut |
| 5. Stem seal box | 12. Wedge |
| 6. NBR O-ring | 13. Body |
| 7. Bonnet | |

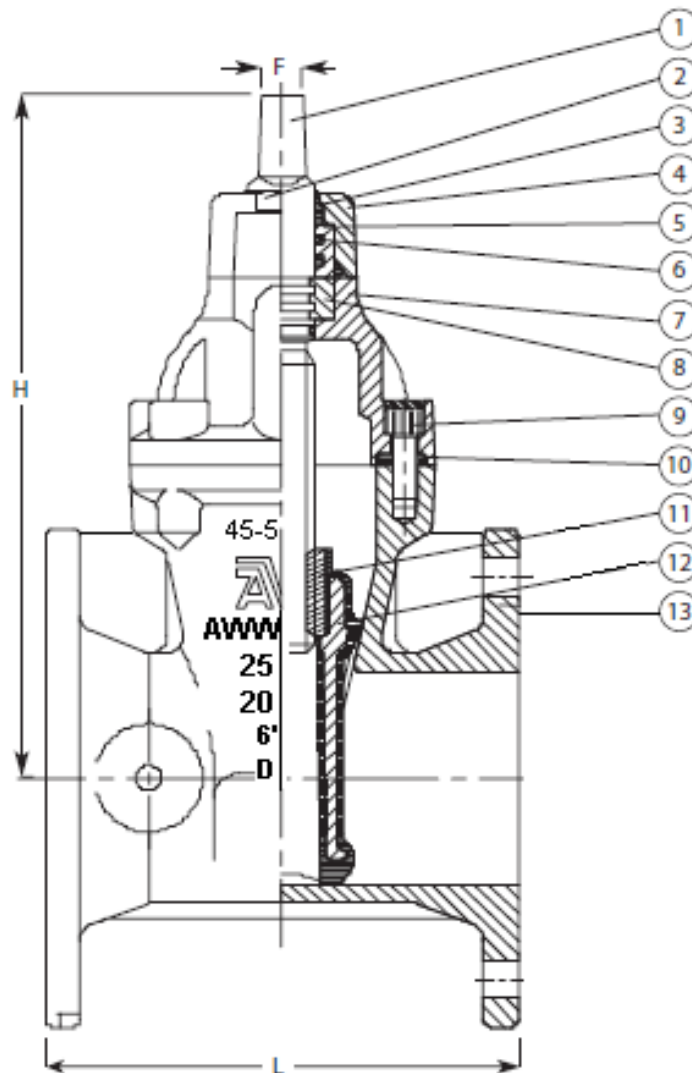

Ref. nos.	DN	L mm	H mm	F mm	Weight kilos
45-050-5D	2"	178	279	19	13
45-080-5D	3"	203	294	19	18
45-100-5D	4"	229	324	19	28
45-150-5D	6"	267	429	24	53
45-200-5D	8"	292	531	27	86
45-250-5D	10"	330	614	27	140
45-300-5D	12"	356	690	27	188
45-350-5D	14"	381	867	32	270
45-400-5D	16"	406	867	32	291